

---

**perFORMA320-360-420** ThermoForm Machinery

---

**perFORMA320-360-420 is functional thermo-form packaging technology**

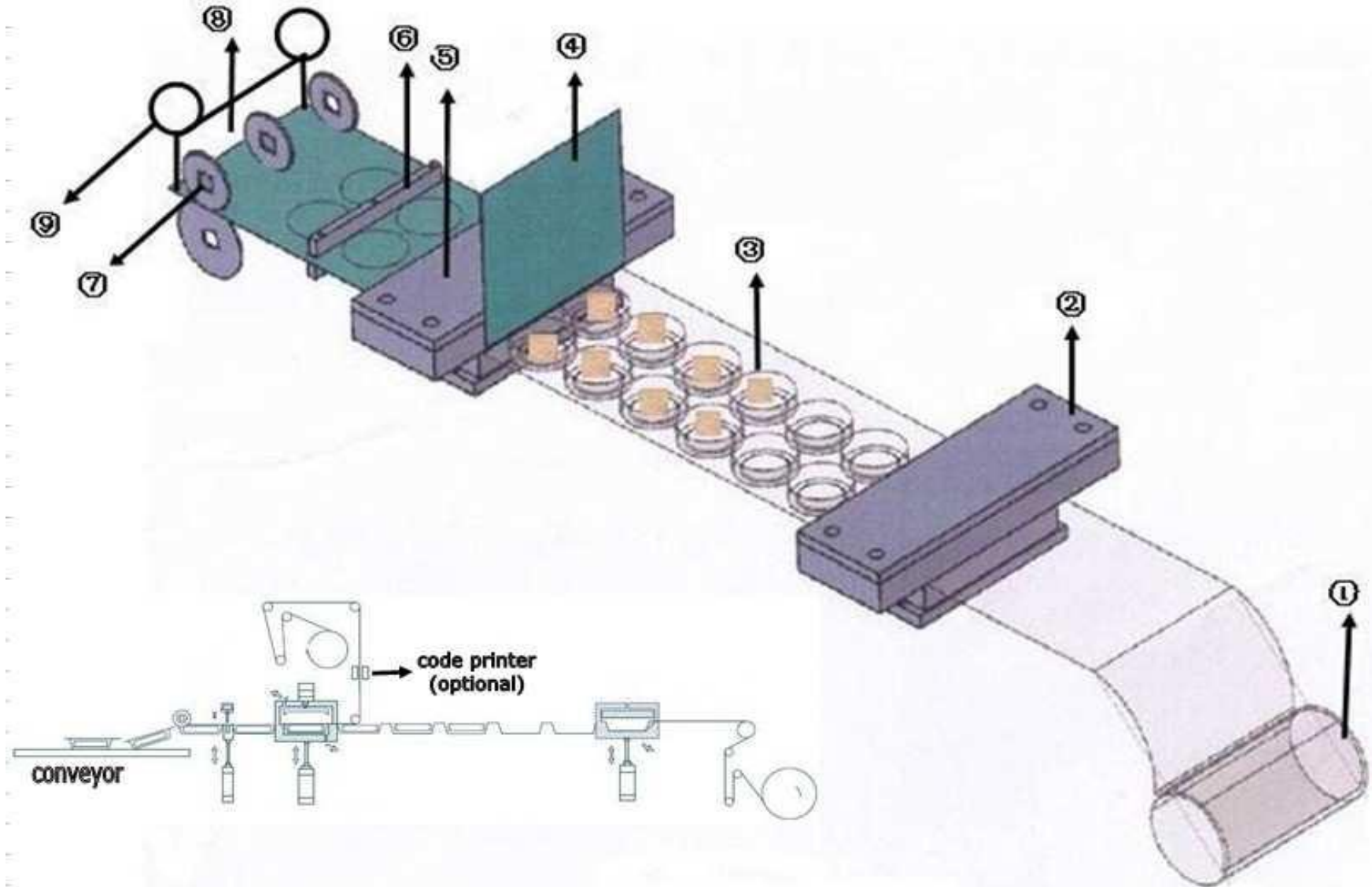

# perFORMA 320

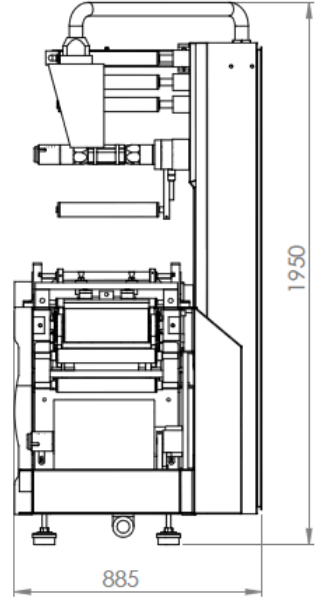
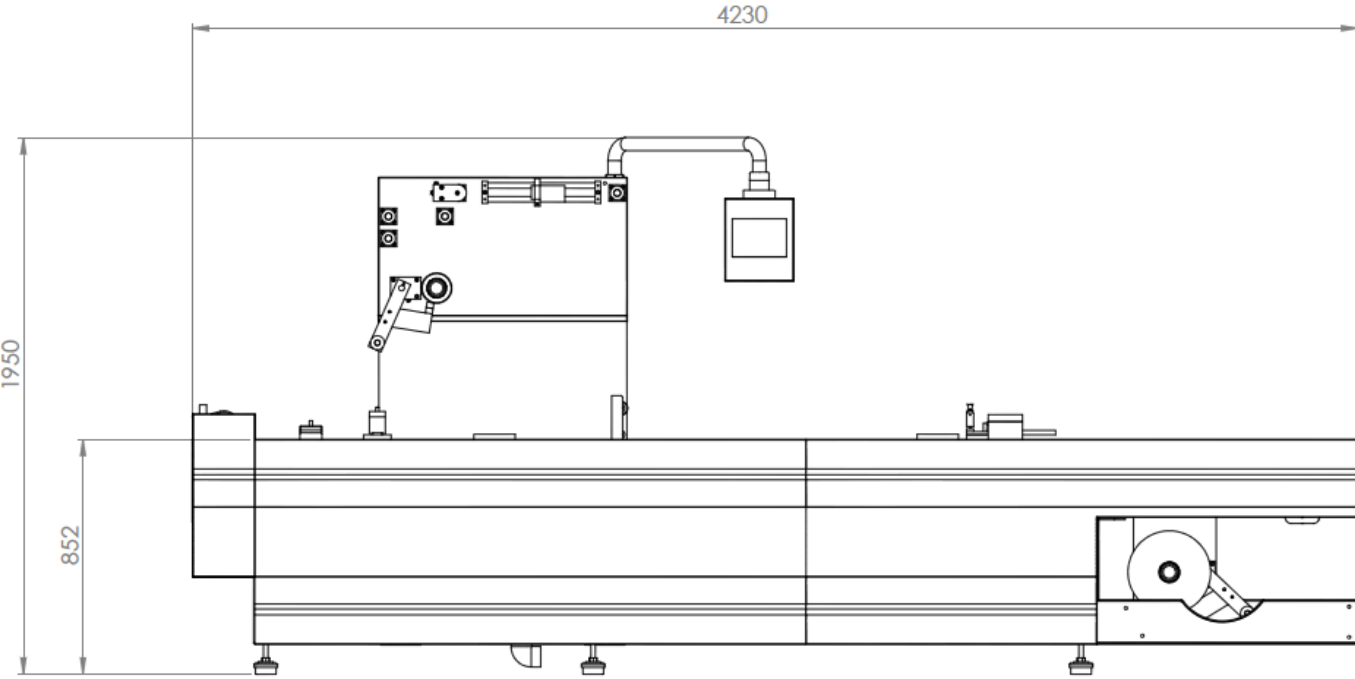

Tecnical chacresterics	perFORMA		
	320	360	420
Length	4.150 mm		
Width	1.070 mm		
Height	1.700 mm		
Power, kW	3/N/PE AC 400V 50 Hz Min 4 > 10 kw		
Airpressure	Min 6 bar 400-600 nl/minute		
Cooling water	60-80 lt/hour		
Lid film Flexible	80-150 mikron		
Forming width	300 mm	340 mm	400 mm
Lid film reel diameter max.	300 mm		
Botton film: Flexible or semi-rigid	130-400 mikron		
Bottom film reel diameter max	350 mm		
Capacity	6-8 işlem/dakika		

	perFORMA			
	200 mm	240 mm	270 mm	300 mm
Standart advance	200 mm	240 mm	270 mm	300 mm
Net loading area	1.000 mm	1.200 mm	1.080 mm	1.200 mm
Number of steps at loading area	5	5	4	4
Thermo-form depth	max 140 mm			
	STANDART		OPTION	
Air pressure form	■		Vacuum 60 m3/h	
Aluminium filler plate	■			
Flat form plate	■			
Rib form plate	no		depends on tool	
Form width	300 mm	340 mm	400 mm	
Vacuum	■		100/160 m3/s	
Gas flash	no		■	
Flat sealing plate	■			
Sealing station filler plate	■			

## Bottom film 320 mm.

### CUT OFF LENGTH / INDEX LAENGE

200

240

270

300

1.1  
H.Max:  
120mm

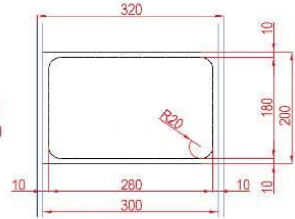

1.1  
H.Max:  
120mm

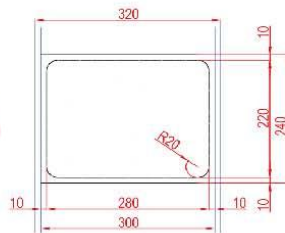

1.1  
H.Max:  
120mm

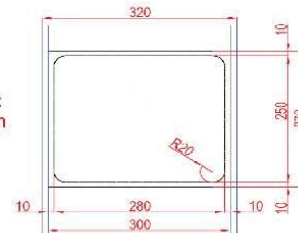

1.1  
H.Max:  
120mm

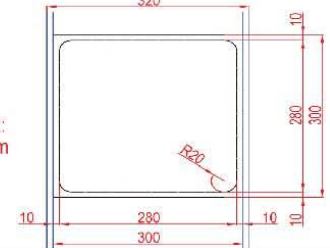

1.2  
H.Max:  
60mm

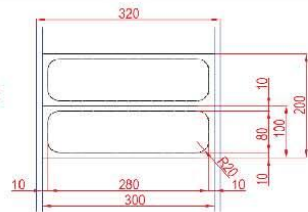

1.2  
H.Max:  
80mm

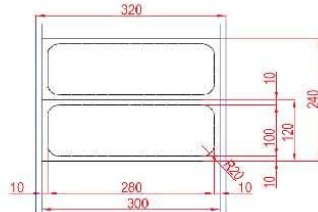

1.2  
H.Max:  
90mm

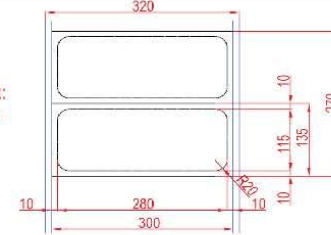

1.2  
H.Max:  
100mm

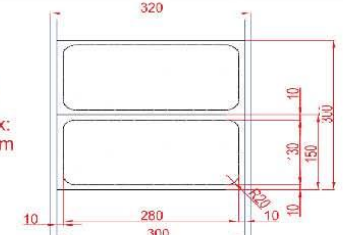

2.1  
H.Max:  
100mm

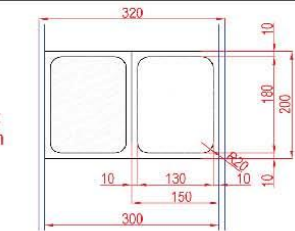

2.1  
H.Max:  
100mm

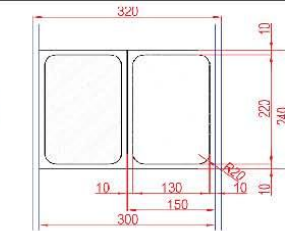

2.1  
H.Max:  
100mm

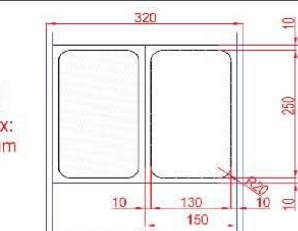

2.1  
H.Max:  
120mm

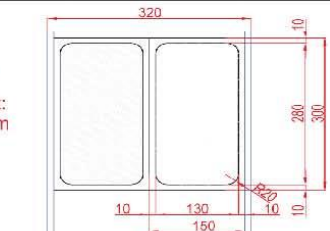

2.2  
H.Max:  
60mm

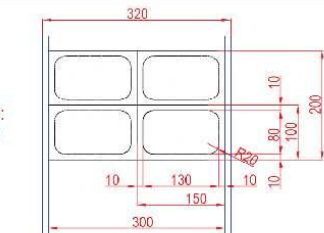

2.2  
H.Max:  
80mm

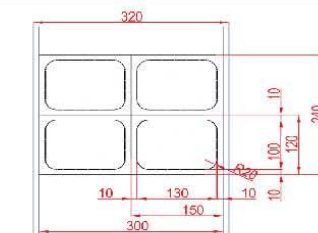

2.2  
H.Max:  
90mm

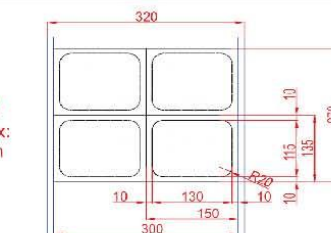

2.2  
H.Max:  
100mm

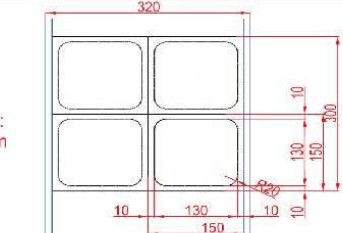

## Bottom film 320 mm.

### CUT OFF LENGTH / INDEX LAENGE

200

240

270

300

3.1  
H.Max:  
60mm

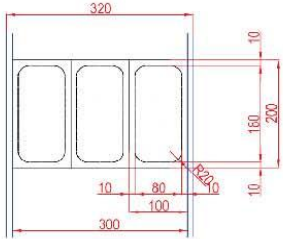

3.1  
H.Max:  
60mm

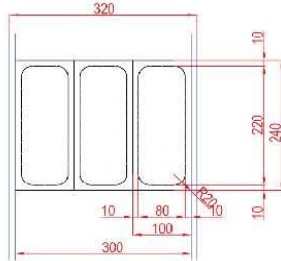

3.1  
H.Max:  
60mm

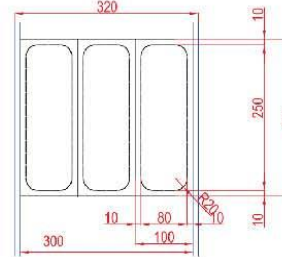

3.1  
H.Max:  
60mm

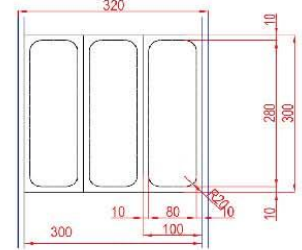

3.2  
H.Max:  
60mm

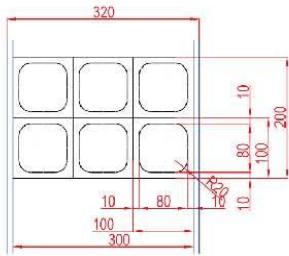

3.2  
H.Max:  
60mm

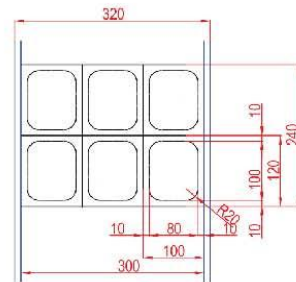

3.2  
H.Max:  
60mm

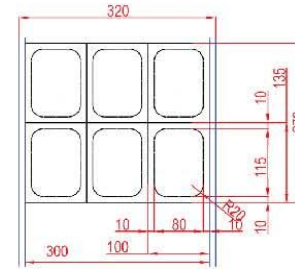

3.2  
H.Max:  
60mm

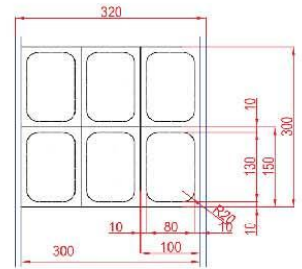

4.1  
H.Max:  
40mm

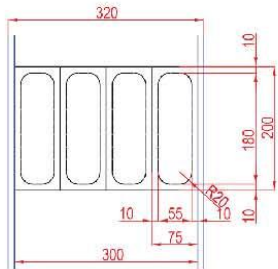

4.1  
H.Max:  
40mm

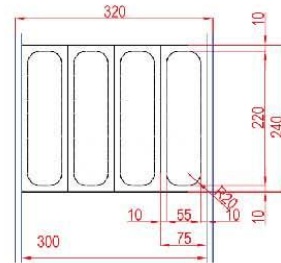

4.1  
H.Max:  
40mm

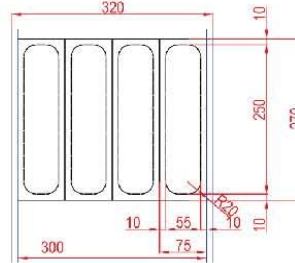

4.1  
H.Max:  
40mm

