

# FUNCTIONAL CHOICES FOR Modified Atmosphere Packaging

*tailor-made integrated packaging design*



AutoMAP 100-200 inline tray sealer is designed for both inline and offline filled products. Seal only, vacuum and modified atmosphere capability provides versatility and increases productivity.

Trays are advanced by stepping motor into sealing mold; sealed, cut and released on to a conveyor. Finished packages are conveyed through indexing, labeling, inkjet coding followed by metal detection and check weigher.

**AutoMAP100-200**

**Tray Sealer**



# IN LINE SOLUTION FOR INCREASED PROFITS

*AutoMAP100 Tray Sealer*

*Quality assurance with current technology*

- Improved Product Shelf-Life
- Outstanding Packaging performance
- Compact and functional design
- High-end quality components
- Versatility in packaging
- Innovative packaging design
- Latest PLC controls
- User-Friendly Touch screen visualization
- Multilingual program

# TECHNICAL SPECIFICATIONS OF THE AutoMAP100



## Technical Data

Power:	max. 8.0 Kw, 400V, 50Hz, 3 PNE AC
Vacuum pump:	105 cbm/h
Air pressure:	6 bar dry
Gas consumption:	35 nl per cycle
Inert gas:	2- 5 bar
Control circuit:	24 vdc
Easy of Use:	Delta DOP-B series touch-screen, PLC, 99 variable program, memory, error message and counter. Eliminate easily; phase, pressure, emergency stop, motor relay, etc.
Language:	Turkish, English and Local Language
Film width:	420 mm
Diameter mandrel:	76 mm
Diameter of roll:	300 mm
Capacity:	7-10 cycle/minute
Optional:	liquid/dust filter
Width of machine:	900 mm
length:	2800-3675 mm
Height:	1663 mm
Loading area:	1.5-3.0 m
Weight:	800 kg
Transport Pack:	1 x pallet 100x400x180cm, approx.1.0 t

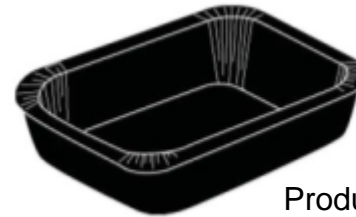

## Technical Capabilities

**ZERO2** can help to reach max vacuum level and minimum oxygen in the pack. It is also possible to pack hot and liquid product via multi-stage vacuum

### All machinery including:

Photocells for printed film  
Gas tank for M.A.P.  
Discharge conveyor; 40 x 200 cm  
Product collection table; diameter 120 cm

### Safety Concept:

Protection equipped with safety switches  
Emergency push button



### Design Concept:

304 Stainless steel machine frame  
CE conformity  
Vacuum pump is placed in the machine frame

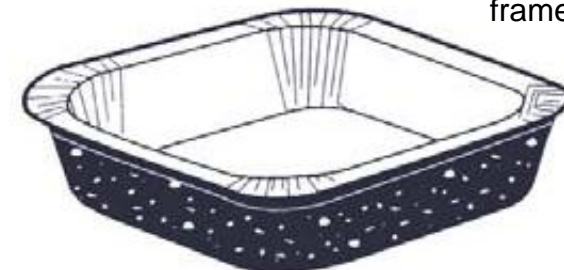



# BRIDGE BETWEEN SCIENCE & PRACTICE



## Special features and functions

- Tool frame including an integrated system to seal and cut according the tray profile.
- Film cut with offset 1,5 mm over the tray rim
- Sealing mark according tray rim surface
- Lower Part with a mold able to contain the tray size
- Heating elements integrated in the surface of heating plate.
- Upper and lower part of the die easy removable with a quick change over system
- Easy connections for electrical power and gas lines



## Standart tray size mm

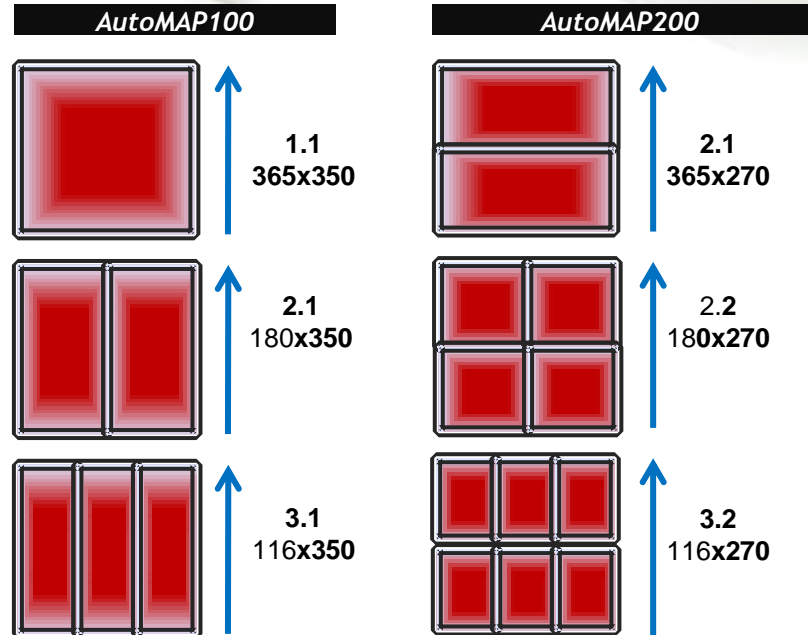

# PLC CONTROL TOUCH SCREEN

Technical Chrasteric



# INLINE PACKAGING AutoMAP100

*Packaging Without Preservatives*

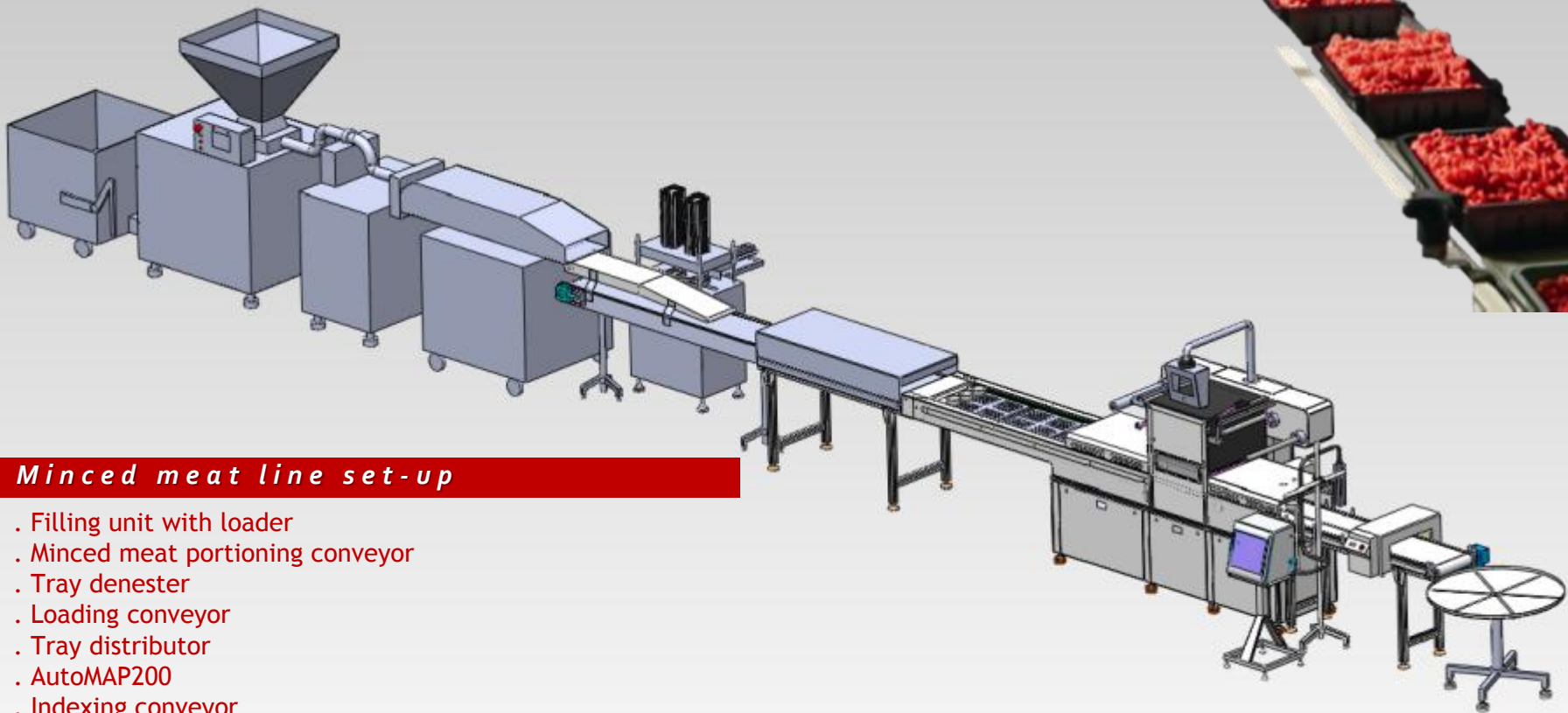

## *Minced meat line set-up*

- . Filling unit with loader
- . Minced meat portioning conveyor
- . Tray denester
- . Loading conveyor
- . Tray distributor
- . AutoMAP200
- . Indexing conveyor
- . Injek printer
- . Metal dedector
- . Product collecting table



# FIELD OF APPLICATION AutoMAP100

*Lid Application Line Set-Up*

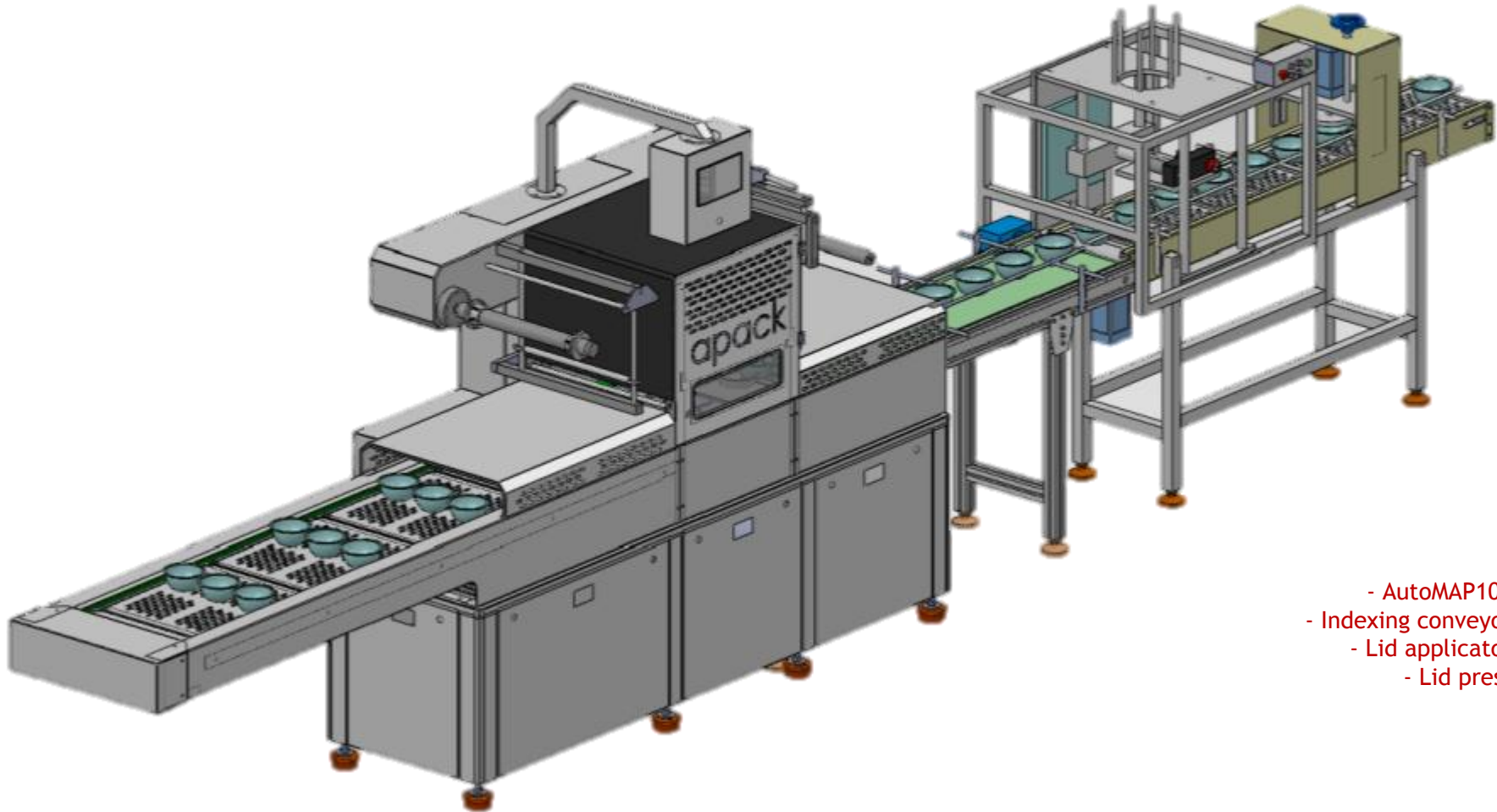

- AutoMAP100
- Indexing conveyor
- Lid applicator
- Lid press

# IMPROVING FOOD SECURITY AutoMAP100

*Multiple applications, but One solution*

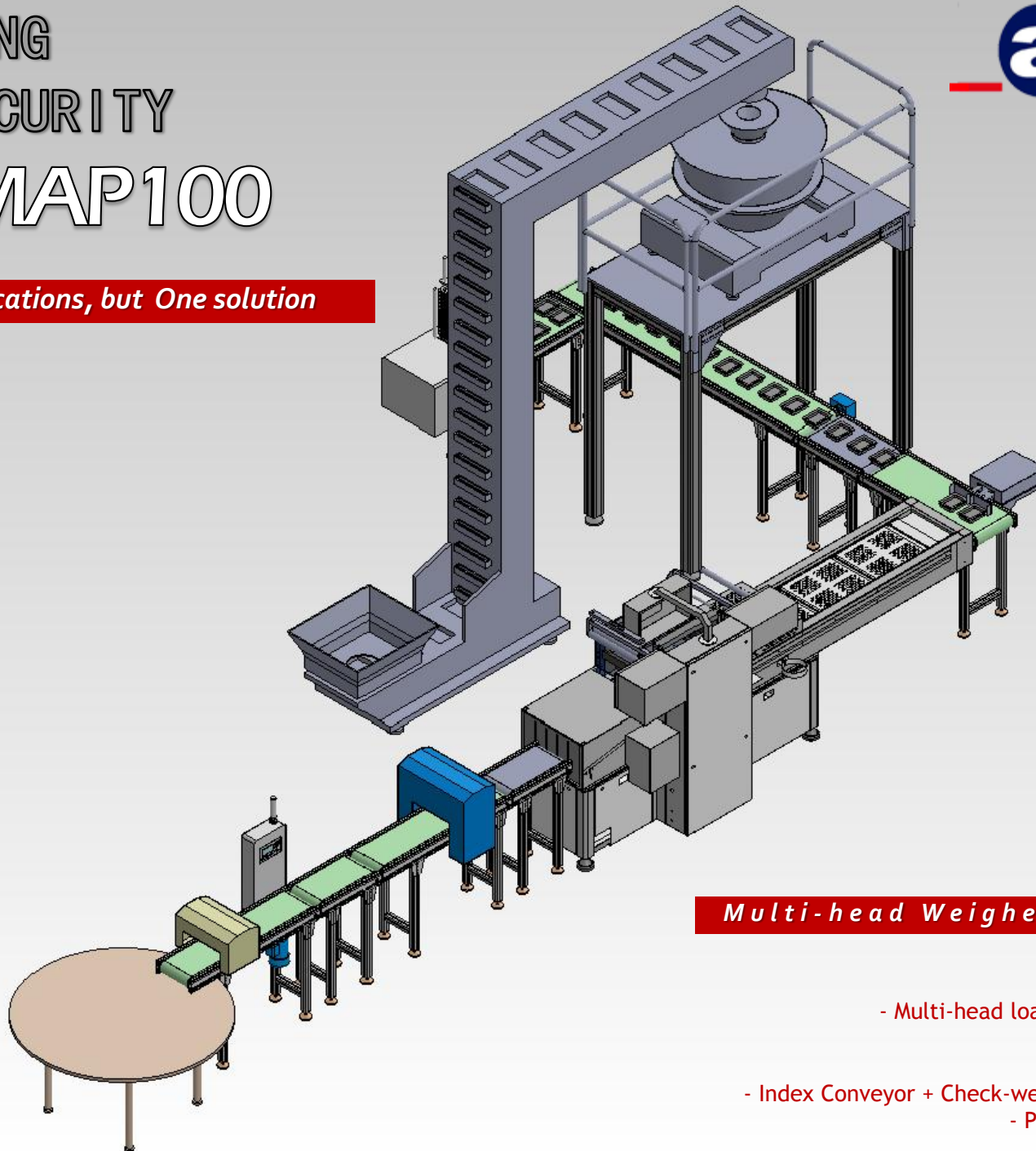

## *Multi-head Weigher Line Set-Up*

- Tray denester
- Transfer conveyor
- Multi-head loader and feed conveyor
- Vibration unit
- AutoMAP100
- Index Conveyor + Check-weigher + metal detector
- Product collection table



FIELD  
OF APPLICATION  
**AutoMAP100**

*Liquid line set-up*

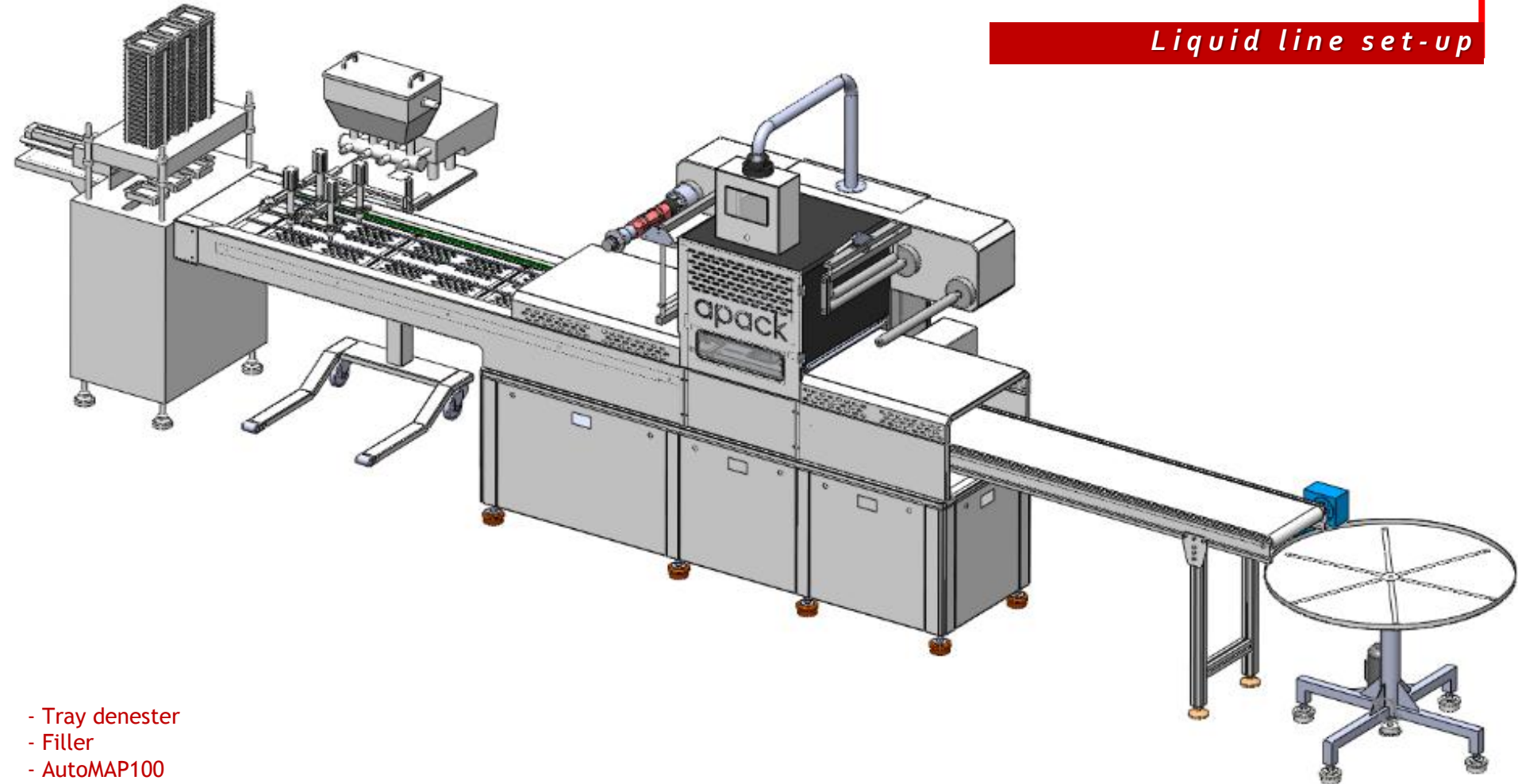

- Tray denester
- Filler
- AutoMAP100
- Indexing conveyor
- Collecting table

# CONTROLLING YOUR BRAND'S TOUCH-POINTS

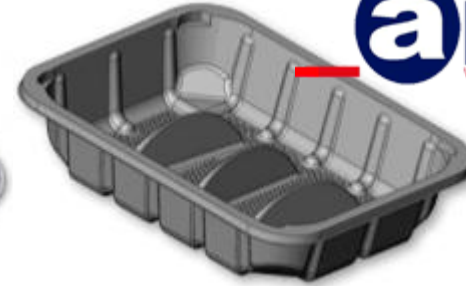

**apack**  
www.apack.com.tr

*Experience, Expertise, Efficiency*

APACK supplies a wide range of solutions for practically all requirements. Depending on the product, you have the choice of three different types of pack as far as the atmosphere is concerned. Product is also presented as attractively and well-protected as possible.

The more appealing the product, the more successful it is. The package type plays a crucial role. It also makes sure the product reaches the customer safe and sound, whether cheese, vegetables, fruit, processed or fresh meat or fish are involved. Another advantage is the improved shelf life. Packaging is an important source of information and relevant messages for your customers.

Packaging from APACK is designed to satisfy our partners' specific requirements. As our customer, you produce the right pack and enjoy the benefits of consistently high quality day in, day out, reliable operating costs and high availability.

## **Customer loyalty thanks to pack design**

Your partner for innovative and appealing food packaging.





# FUNCTION & DESIGN OF PACKAGES

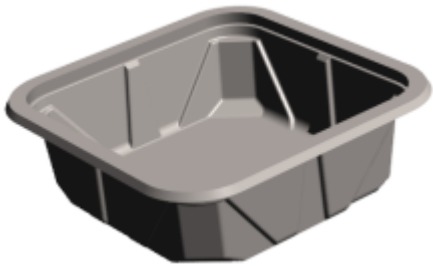

# MAKE A DIFFERENCE

## Total solution

One of the package key features is to protect the product during transport and storage. The packaging is also the only way to attract consumer's attention in the market. The package is used to communicate the quality of the packaged product and at the an attractive, striking pack design-based, for example on eye-catchingly printed film or specially designed labels – is remembered by the consumer so well that he recognizes the product again easily after he has finished eating. Controlled opening aids, re-closable or simple portion size are example of further design features that draw attention to quality of the packaged goods.





# Positioning and Packaging Your Product

## Critical Do's and Don'ts

*Meat substitutes have a long way to go*



“Packaging's crucial role in protecting product integrity, on the one hand, and the environmental implications of packaging waste generation, on the other hand, must be considered in an integrated way, based on life-cycle thinking”





# IMPROVING Food SECURITY

New life-styles and demographic structures are driving important changes in the demand for different products and packaging types. The food and drink industry is responding to this changing needs and is adjusting products and packaging accordingly

*The challenge*

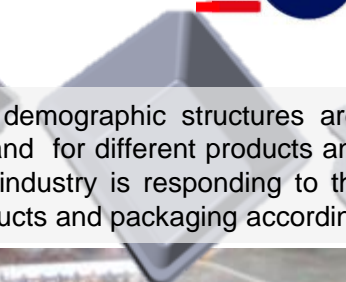

**INNOVATIVE PACKAGING SOLUTIONS for Food Industry, Catering and Take-away**



# Developing Key Strategic Customer Partnerships.....

## The Range

APACK produces one of the highest quality packaging machine and flexible film ranges in the Turkey and export . Our AutoMAP100 standard range of products have been developed according request to ensure quality -products protection.

## Capability

We constantly over deliver. Production quality, customer focus and design innovation ensures our solution are the best they can be. We have the capability to turn your requirement into reality with the minimum of fuss, time and cost.

## Possibilities

Your product must reach the consumer in pristine condition, adding to the overall value and shelf presence. APACK team create visually stunning yet practical tray solutions. The possibilities...endless..

## Customer services

We pride ourselves in our attention to detail and customer care. we offer functional solution , quick delivery and a complete after sale support & service culture.

